

DN (mm)	NPS (in)	L	O	W	R	d	t _f	h	n	Ø	H	E	Gewicht (kg)
Class300													
50	2	216	165	127	92,1	50	20,7	2	8	19	354	200	23
65	2,5	241	190	149,2	104,8	63	23,9	2	8	22	394	200	32
80	3	282	210	168,3	127	76	27	2	8	22	422	250	50
100	4	305	255	200	157,2	100	30,2	2	8	22	495	280	71
125	5	381	280	235	185,7	125	33,4	2	8	22	570	300	100
150	6	403	320	269,9	215,9	150	35	2	12	22	656	350	144
200	8	419	380	330,2	269,9	200	39,7	2	12	25,5	825	400	209

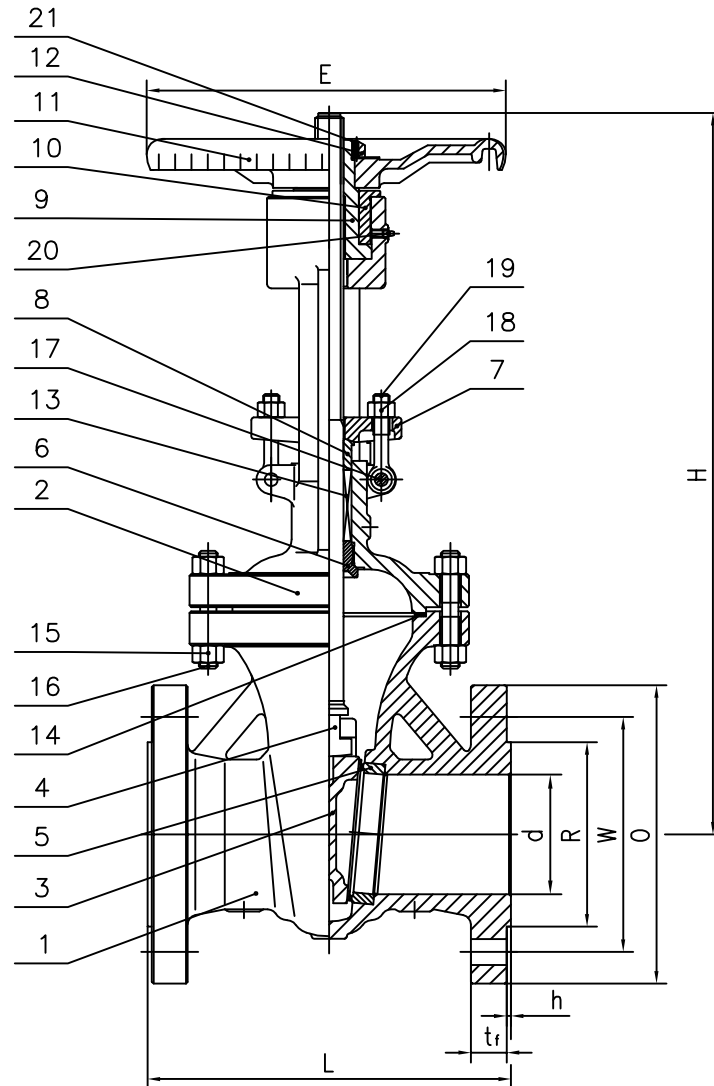

Item	Parts name	Bezeichnung	Material
1	Body	Gehäuse	A216 WCB/1.0619
2	Bonnet	Deckel	A216 WCB/1.0619
3	Wedge	Schieberplatte	A216 WCB/1.0619 + 13 Cr
4	Stem	Spindel	A182 F6a
5	Seat Ring	Sitzring	A105 + 13 Cr
6	Back Seat Ring	Rückdichtung	A182 F6a
7	Gland Flange	Stopfbuchsbrille	A216 WCB
8	Gland	Stopfbuchse	A276 410
9	Stem Nut	Gewindebuchse	B148 C95200
10	Retaining Nut	Lagermutter	AISI 1035
11	Handwheel	Handrad	A536 60-40-18
12	Handwheel Nut	Handradmutter	AISI 1035
13	Stem Packing	Packung	Graphite + 304
14	Bonnet Gasket	Deckeldichtung	Graphite + 304
15	Bonnet Nuts	Deckelmuttern	A194 2H
16	Bonnet Bolts	Gewindebolzen	A193 B7
17	Hinge Pin	Stift	AISI 1035
18	Gland Nuts	Stopfbuchsmuttern	A194 2H
19	Gland Eyebolt	Stopfbuchsenringschraube	A193 B7
20	Oil Cup	Schmiernippel	SS
21	Screw	Gewindestift	CS

Specification	
Shell Test Pressure	76,7
High Pressure Seal Test	56,2
Low Pressure Seal Test	6
Suitable Temperatur	-29 ~ 425°C
Suitable Medium	Water, Steam, Oil etc.

Face-to-face dimensions/Baulänge: ASME 16.10	Design and manu. API600	Design by: DZ	Checked by: RS	Date: 23.08.17
Type: Gate Valve TOPAS ANSI				
Class/Druckstufe: 300	Size/Nennweite: 2"-8" inch			
Flanged ends dimensions/Flanschmaße: ASME B16.5	Rev: 1			

kihsco
Valves Europe GmbH